

 Fichet Bauche®

# Atrius

Safe  
Burglary Protection



Certified  
burglary  
resistance



[www.fichet-bauche.com](http://www.fichet-bauche.com)

# ATRIUS

## Burglary Protection

Based on our premium InviKtus range, Atrius safes offer an ideal solution to equip business premises and other professional environments with high security requirements. Thanks to an exclusive barrier material developed by Fichet-Bauche's R&D teams, Atrius safes deliver high levels of resistance to burglary while preserving an optimum weight/security performance ratio.



## Key features

### PROTECTION

- ✦ Certified burglary resistance as per EN 1143-1 (Grades IV-V)

### CAPACITY

- ✦ 140 litres
- ✦ 200 litres
- ✦ 300 litres
- ✦ 400 litres
- ✦ 600 litres

### KEY BENEFITS

- ✦ High levels of burglary resistance
- ✦ Optimum weight/security performance ratio thanks to patented innovative materials.

## Fichet-Bauche guarantees

Our products are subjected to the most stringent tests approved by insurers and A2P-certified by France's National Centre for Prevention and Protection (CNPP). This is the result of integrating our own test laboratory into our factory to impose conditions going even further than those of certifying bodies. Installation is also carried out by our own technicians to ensure certification of your safe is always preserved.

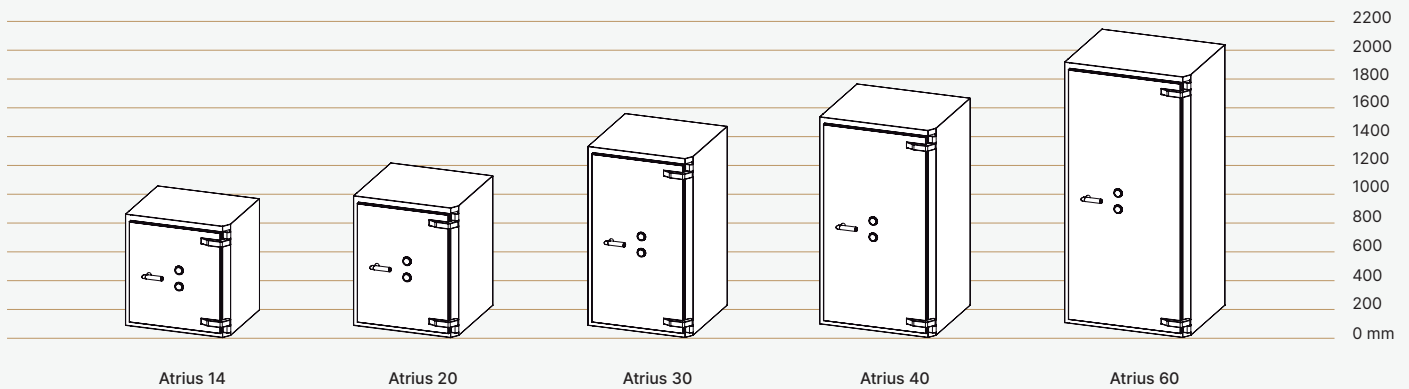

## Technical specifications

Modèles		Atrius 14	Atrius 20	Atrius 30	Atrius 40	Atrius 60
Capacity (Litres)		139	210	308	416	596
External Dimensions (mm) Hinges projection not included	Height	790	920	1270	1470	1850
	Width	730	730	730	810	880
	Total width with door open to 180°	1420	1420	1420	1580	1720
	Depth (without handle & locks)	640	740	740	740	740
	Total depth with door open to 90°	1283	1383	1383	1463	1533
Internal dimensions (mm)	Height	620	750	1100	1300	1680
	Clearance height (mm)	572	702	1052	1252	1632
	Width	560	560	560	640	710
	Clearance width	512	512	512	592	662
	Clearance width (door open to 90°)	510	510	510	590	660
Weight (kg)	Grade IV	603	760	985	1201	1558
	Grade V	609	767	999	1217	1575
Number of shelves		2	3	3	4	5
Number of doors		1				

Handle projection: +65mm / Lock projection: +14-57mm depending on models.

## Fichet Locks

A2P-certified locks as per European standards EN 1300.  
Standard safes are equipped with 2 Grade-B certified locks:  
1 MxB-B keylock and 1 mechanical/electronic lock



MxB-B key lock  
(patented by Fichet-Bauche)



Moneo mechanical  
combination lock



Nectra electronic  
combination lock



KelNet electronic  
combination lock

## A hallmark of our brand

With 200 years of experience as master locksmiths, we develop and manufacture our own exclusive locks. This is one of the key strengths of our safes and a guarantee of high security. We remain committed to permanent investment in R&D, always looking for more functionality, more resistance, new materials and more advanced lock technologies.

## Product details

Fichet's Atrius range is designed for simplicity of use and practicality: handle to the left, key to the right, controls at the top. Their ergonomic handle provides an ideal grip for easy opening and full access to contents.

### PERFORMANCE AND SECURITY

Atrius safes offer:

- ✦ Burglary resistance as per EN 1143-1 certified by A2P and ECB-S (Grades IV and V with €110,000 and €200,000 insurance ratings respectively)
- ✦ Choice of mechanical and/or electronic locks (all A2P-certified as per EN 1300)
- ✦ Bolt movement driven by door handle
- ✦ Robust steel bolts and reinforced hinges specifically designed to resist modern methods of attack
- ✦ Optional factory-installed alarm configurations for remote lock management: DOCT sensors for shock and thermal opening detection - compatible with most centralised alarm platforms – allow for 24/7 monitoring and detection

### INTERIOR FITTINGS AND OPTIONS

- ✦ Standard or reinforced shelves
- ✦ Shelves for suspension files frames
- ✦ Lockable compartments
- ✦ Lockable drawer
- ✦ DOCT alarm sensors
- ✦ Anchoring kit included for safes weighing less than 1,000kg (mandatory as per EN 1143-1 requirements).

